

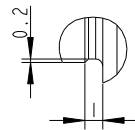

SEE DETAIL A

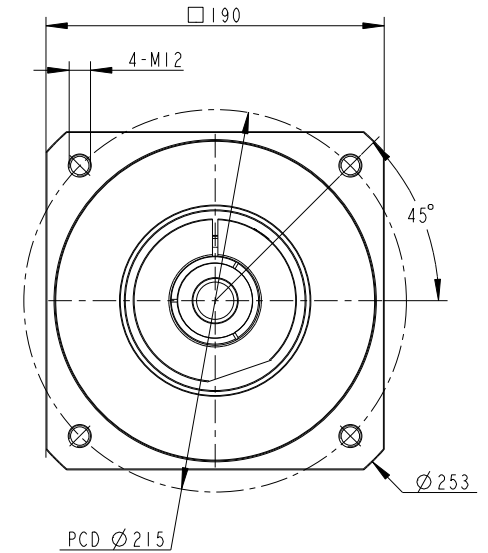

DETAIL A
SCALE 10:1

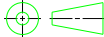

INERTIA: 14.96 ~ 17.2 kg-cm²
MASS: 16.8 Kg

PART NO. PE2-155_IST_42-P0411A00101 AD-PE2-S42-M190-1		 APEX DYNAMICS, INC.		
APPROVALS	DATE	TITLE PE2-155_1 Stage_S42 , RATIO= 3-10 AND MOTOR FLANGE MOUNTING		
DRAWN 沈正義		DWG NO. PE2-155_IST_42-P0411A00101		
CHECKED				
APPROVED			SIZE A0	SCALE 1:1
				REV