

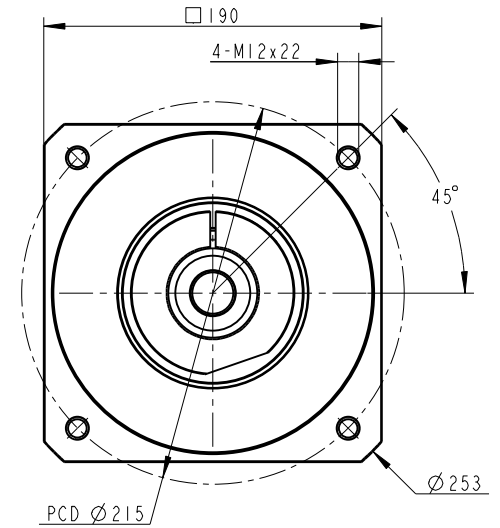



DETAIL A
SCALE 10:1



INERTIA: 14.96 ~ 17.2 kg-cm²
MASS: 17.1 Kg

PART NO. PG2-160_1ST_42-P0411A00101 AD-PE2-S42-M190-1		 APEX DYNAMICS, INC.			
APPROVALS	DATE	TITLE PG2-160_1 Stage_S42 , RATIO= 3~10 AND MOTOR FLANGE MOUNTING			
DRAWN 萬復志					
CHECKED		DWG NO. PG2-160_1ST_42-P0411A00101			
APPROVED		 	SIZE A0	SCALE 1:1	REV